



LRI512

13.56 MHz, ISO 15693, Contactless Memory Chip 512 bit EEPROM with Inventory, 64bit UID and EAS

DATA BRIEFING

- ISO15693 Standard: Fully Compliant
- 13.56 MHz ± 7 kHz Carrier Frequency
- To the LRI512:
 - 10% or 100% ASK modulation using:
 - 1/4 pulse position coding (26 kbit/s)
 - 1/256 pulse position coding (1.6 kbit/s)
- From the LRI512:
 - Load modulation using Manchester coding with 423 kHz and 423/484 kHz sub-carrier in:
 - Fast data rate (26 kbit/s)
 - Low data rate (6.6 kbit/s)
- Internal Tuning Capacitor
- 512 bit EEPROM with Block Lock Feature
- 64 bits Unique Identifier (UID)
- EAS features
- READ block and WRITE block (32-bit blocks)
- 5 ms Programming Time (typical)
- More than 100,000 Erase/Write Cycles
- More than 40 Year Data Retention

DESCRIPTION

The LRI512 is a contactless memory, powered by a radio frequency electromagnetic wave transmitted by the Reader device.

The LRI512 is a 512 bit Electrically Erasable Programmable Memory (EEPROM) fabricated with STMicroelectronics' High Endurance Single Polysilicon CMOS technology. The memory is organised as 16 blocks of 32 bits.

Data are exchanged between the LRI512 and the Reader by modulating the 13.56 MHz carrier frequency. Incoming data are demodulated from the received signal amplitude modulation (ASK, Amplitude Shift Keying). Outgoing data are generated by the antenna load variation using the Manchester coding using one or two sub-carrier frequencies. The received ASK wave is 10% or 100% modulated (amplitude modulation). The

Table 1. Signal Names

AC1	Antenna Coil
AC0	Antenna Coil

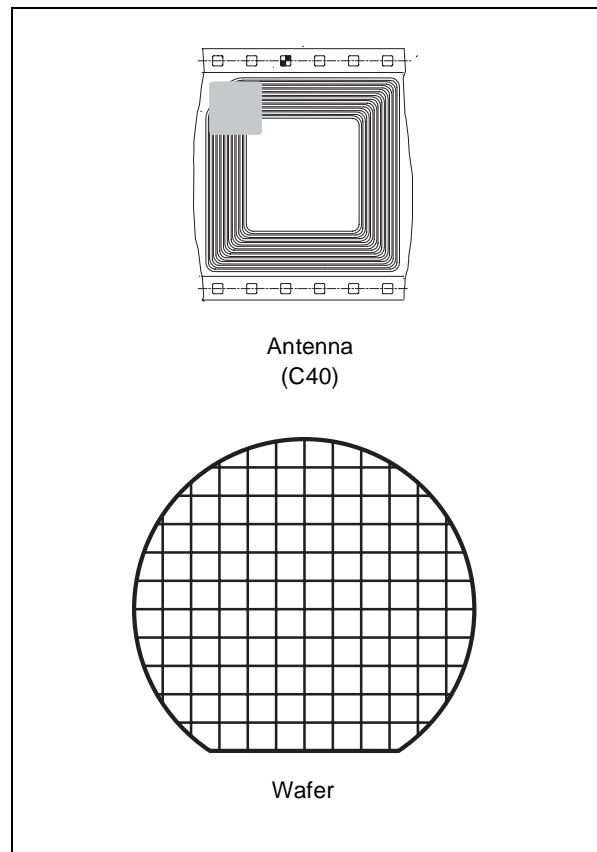
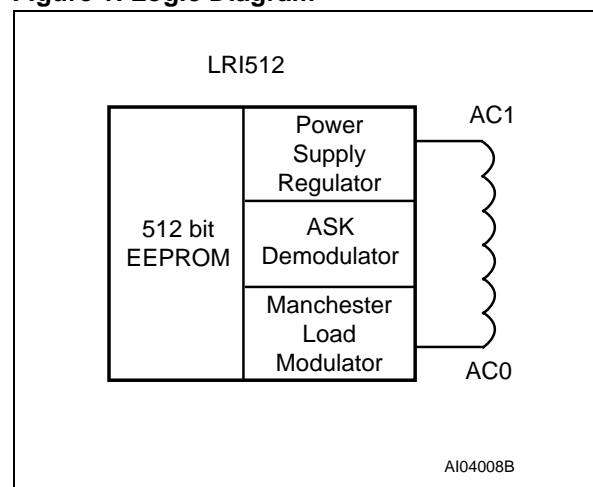

Figure 1. Logic Diagram



Data transfer rate between the LRI512 and the Reader is 1.6 kbit/s using the 1/256 pulse coding mode and 26 kbit/s using the 1/4 pulse coding modes.

The LRI512 follows the ISO15693 recommendation for radio frequency power and signal interface.

MEMORY MAPPING

The LRI512 is divided in 16 blocks of 32 bits, for the user area, plus 2 blocks of 32 bits, which stores the 64-bit Unique Identifier (UID), and an 8-bit AFI register, which stores the Application Family Identifier used by the anticollision algorithm. Each user block can be individually Write Protected using a specific Lock command.

The first block (location 0) can be used to store a certificate (CER) in order to secure the memory validation. Using the Unique Identifier (UID) value (UID), a master Key (MK) and a mathematical function (FCER), it is possible to calculate the certificate

$$CER = F_{CER} (UID, MK)$$

Table 2. LRI512 Memory Map

Address	0	7	8	15	16	23	24	31
0	CERTIFICATE (CER)							
1	User Block							
2	User Block							
3	User Block							
4	User Block							
5	User Block							
6	User Block							
7	User Block							
8	User Block							
9	User Block							
10	User Block							
11	User Block							
12	User Block							
13	User Block							
14	User Block							
15	User Block							

UID0	UID1	UID2	UID3
UID4	UID5	UID6	UID7
AFI			

An extra 64-bit block provides the Unique Identifier (UID) of the LRI512, set by ST. This UID is compliant to the ISO15963 description. Its value is used during the anti-collision sequence (INVENTORY).

The User Area consists of blocks that are always accessible in READ. WRITE commands are possible if the block is not locked. For all WRITE commands, all the 32 bits of the block are updated by the new 32-bit value. A WRITE command invokes an auto-Erase cycle.

COMMANDS

The following commands are supported:

- **INVENTORY**: used to perform the anti-collision sequence.
- **STAY QUIET**: to put the LRI512 in quiet mode. The LRI512 is then deselected and does not respond to any command.
- **SELECT**: used to select the LRI512. After this command, the LRI512 is available to process all READ/WRITE commands, provided that the Select flag is set.
- **READ BLOCK**: to output the 32 bits of the selected block.
- **WRITE BLOCK**: to write the 32-bit value in the selected block, provided that it is not locked.
- **LOCK BLOCK**: to lock the selected block. After this command, the block can no longer be modified.
- **WRITE AFI**: to write the 8-bit value in the AFI register, provided that it is not locked.
- **LOCK AFI**: to lock the AFI register.
- **ACTIVATE EAS**: to set the non volatile EAS bit. When the EAS bit is set, the LRI512 answers to the POOL EAS command.
- **DEACTIVATE EAS**: to reset the non volatile EAS bit, so that the LRI512 no longer answers to the POOL EAS command.
- **POOL EAS**: used to request all LRI512s in the Reader field to generate the EAS signal, provided that their EAS bit is set.

INITIAL DIALOGUE FOR VICINITY CARDS

The dialogue between the Vicinity Coupling Device (VCD) and the Vicinity Integrated Circuit Card (LRI512) is conducted through the following consecutive operations:

- activation of the LRI512 by the RF operating field of the VCD.
- LRI512 waits silently for a command from the VCD.
- transmission of a command by the VCD.
- transmission of a response by the LRI512.

This technique is called Reader Talk First (RTF).



Table 3. Ordering Information Scheme

Example: LRI512 - C40 / xxx

Delivery Form		Transfer Code
C40	Antenna on Super 35 mm tape	Given by ST
W4	180 μm \pm 15 μm unsawn wafer	

ORDERING INFORMATION

The notation used for the device number is as shown in Table 3. For a list of available options (speed, package, etc.) or for further information on any aspect of this device, please see the current Memory Shortform Catalogue, or contact your nearest ST Sales Office, or email:

memories.contactless@st.com